

Endo-Model[®] Revision Stems &
XL Prosthesis Stems Lubinus SPII[®]

Presented by:



CE 0123

Waldemar Link GmbH & Co. KG

Barkhausenweg 10 · 22339 Hamburg, Germany

P.O. Box 63 05 52 · 22315 Hamburg, Germany

Tel.: +49 40 53995-0 · Fax: +49 40 5386929

E-mail: info@linkhh.de · www.linkorthopaedics.com

Endo-Model[®] Revision Stems XL Prosthesis Stems Lubinus SPII[®]

	Description
02	System Description
03	Indications/Contraindications
	Implants
04	Endo-Model [®] Revision Stems, anatomical
06	Endo-Model [®] Revision Stems, straight
08	XL Prosthesis Stems Lubinus SPII [®] , anatomical
10	XL Prosthesis Stems Lubinus SPII [®] XL Neck
12	Prosthesis Heads
	Instruments
13	Colored Plastic Trial Heads
14	Instruments for Hip Implantation
	Surgical Technique
20	Preoperative Planning
20	Surgical Technique
	Accessories
23	X-ray Templates
23	Instructions of Cleaning and Maintenance
23	Literature
26	Nummerical Index
	Important Information

■ System Description



The number of primary hip prostheses implanted each year throughout the world continues to grow. Alongside these primary replacements, the number of revision operations is increasing at a percentage in double figures. It is clear that both the number and the complexity of revision operations will grow strongly in the short and medium term.

A range of cementable revision hip prosthesis stems is available for this group of patients. They differ markedly from primary hip prostheses in their design and function and in the surgical techniques used for their implantation. These differences often call for an individual approach when identifying indications, planning the operation, choosing surgical techniques and caring for patients after surgery.

Endo-Model® Revision Stems are available as right and left side versions (anatomical design) with a 12/14 mm taper and stems lengths of 170-300 mm. The three different stem thicknesses have a CCD angle of 135°. The design of the stem includes a collar with a toothed side towards the bone that improves bonding with the proximal end of the femur, thus protecting the cement layer and ensuring that forces incorporate the proximal end of the femur.

Endo-Model® Straight Revision Stems, modular, have a 12/14 mm taper and are available in lengths of 130-300 mm with 2 different CCD angles (126° and 135°) and a large neck plate to cover wide open proximal femur ends.

XL Prosthesis Stems Lubinus SPII® with a 12/14 mm taper, are available as right and left side versions (anatomical design) with stems lengths of 200-350 mm and in 3 different stem thicknesses (medium to extra large) with CCD angles of 126° and 135°.

XL Prosthesis Stems Lubinus SPII® XL are available in three thicknesses (medium to extra large). The neck lengths are 10 mm longer than those of the XL Prosthesis Stems Lubinus SPII®.

■ Indications/Contraindications

■ Indications/Contraindications

Cementable revision hip stems are often used after loosening of femoral hip implants, after sub- or periprosthetic fractures or after reconstruction to correct proximal bone defects.

Note:

[See page 25 for specific indications / contraindications](#)

■ **Endo-Model® Revision Stems, anatomical**

Material: CoCrMo, taper 12/14 mm

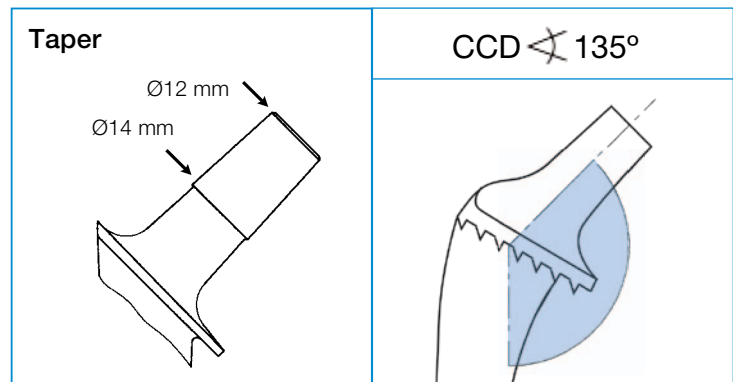

Each stems bears an identification mark on the upper side of the collar consisting of one letter and one number.

- R** = right
- L** = left
- 1** = extra large
- 2** = large
- 3** = normal

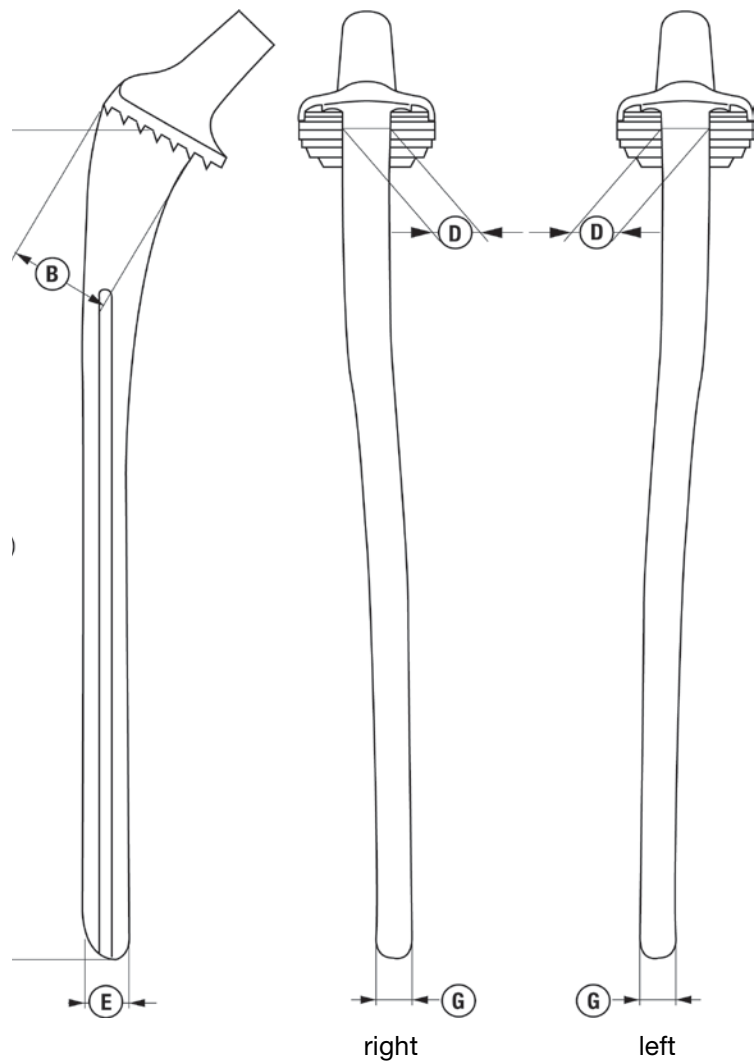

■ Implants

■ Endo-Model® Revision Stems, anatomical

Material: CoCrMo, taper 12/14 mm

Item no.	Version	Stem length C mm	Stem size	Measurements B mm	D mm	E mm	G mm
15-1717/01*	right	300	1	29.0	14.0	12.5	9.5
15-1717/03*	right	300	2	29.0	13.0	10.5	8.0
15-1717/05*	right	300	3	29.0	13.0	9.0	7.0
15-1717/11*	right	250	1	29.0	14.0	12.5	9.5
15-1717/13*	right	250	2	29.0	13.0	10.5	8.0
15-1717/15*	right	250	3	29.0	13.0	9.0	7.0
15-1717/21*	right	200	1	29.0	14.0	10.5	7.0
15-1717/23*	right	200	2	29.0	13.0	10.5	7.0
15-1717/25*	right	200	3	29.0	13.0	9.0	7.0
15-1717/31*	right	170	1	29.0	14.0	10.5	7.0
15-1717/33*	right	170	2	29.0	13.0	10.5	7.0
15-1717/35*	right	170	3	29.0	13.0	9.0	7.0
15-1717/02*	left	300	1	29.0	14.0	12.5	9.5
15-1717/04*	left	300	2	29.0	13.0	10.5	8.0
15-1717/06*	left	300	3	29.0	13.0	9.0	7.0
15-1717/12*	left	250	1	29.0	14.0	12.5	9.5
15-1717/14*	left	250	2	29.0	13.0	10.5	8.0
15-1717/16*	left	250	3	29.0	13.0	9.0	7.0
15-1717/22*	left	200	1	29.0	14.0	10.5	7.0
15-1717/24*	left	200	2	29.0	13.0	10.5	7.0
15-1717/26*	left	200	3	29.0	13.0	9.0	7.0
15-1717/32*	left	170	1	29.0	14.0	10.5	7.0
15-1717/34*	left	170	2	29.0	13.0	10.5	7.0
15-1717/36*	left	170	3	29.0	13.0	9.0	7.0

* Also available with 14/16 mm taper on request.

■ **Endo-Model® Revision Stems, straight**

Material: CoCrMo, taper 12/14 mm

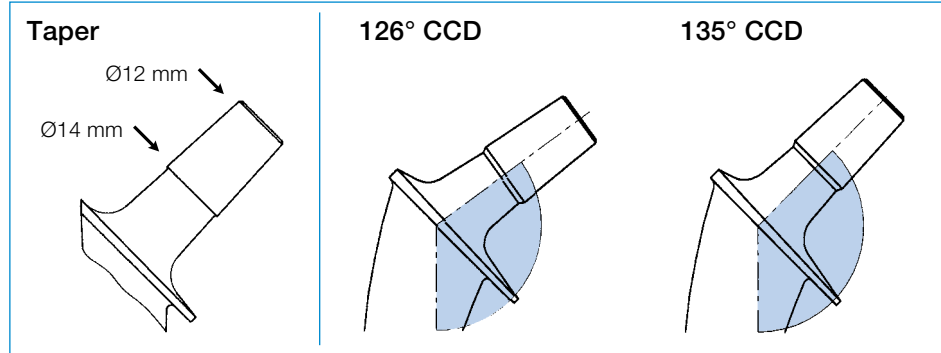

- straight stems
- 6 stem lengths
- 2 CCD angles

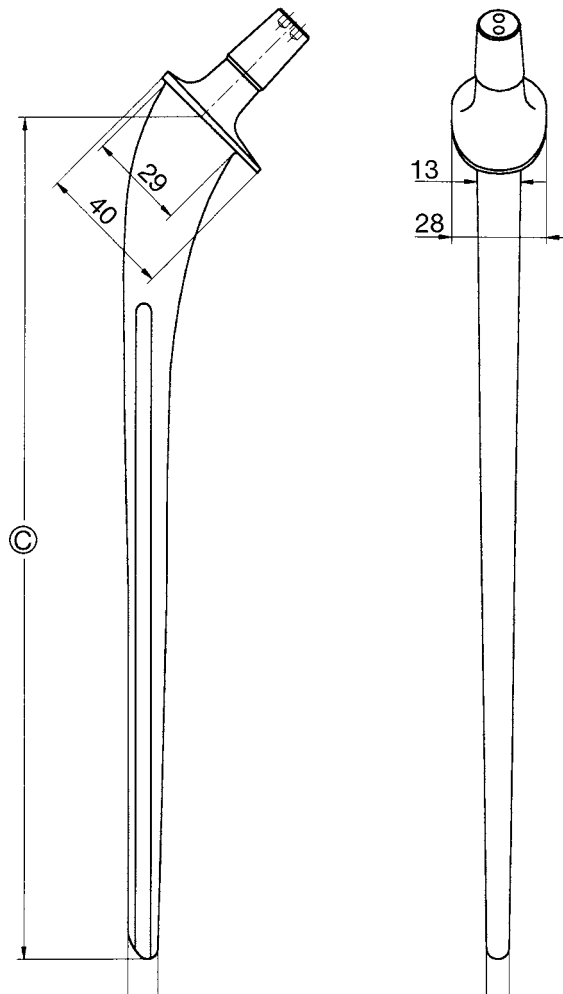

■ Implants

■ Endo-Model® Revision Stems, straight

Material: CoCrMo, taper 12/14 mm

Item no.	Item no.	Version	Stem length ⊙ mm
125-500/26	125-500/35	straight	130
125-505/26	125-505/35	straight	150
125-510/26	125-510/35	straight	170
125-515/26	125-515/35	straight	200
125-520/26	125-520/35	straight	250
125-525/26	125-525/35	straight	300

■ **XL Prosthesis Stems Lubinus SPII®, anatomical**

Material: CoCrMo, taper 12/14 mm

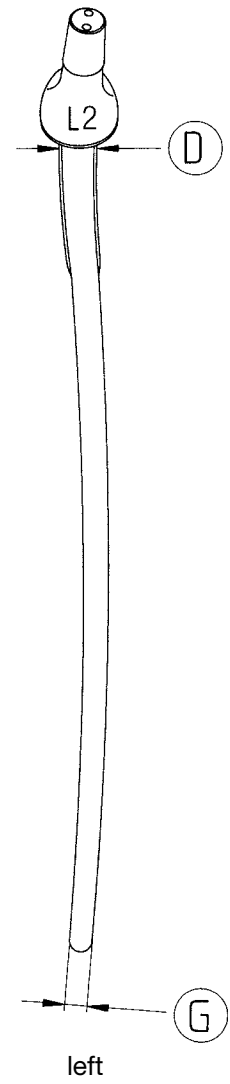
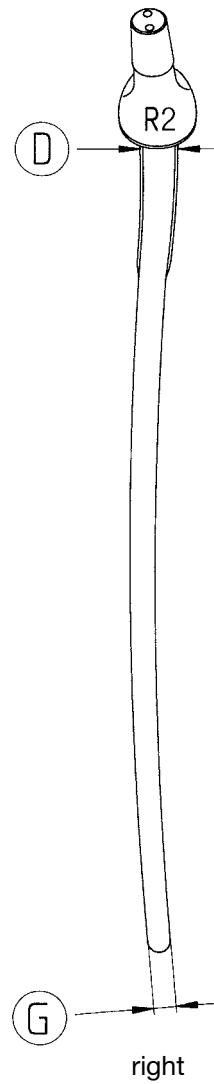
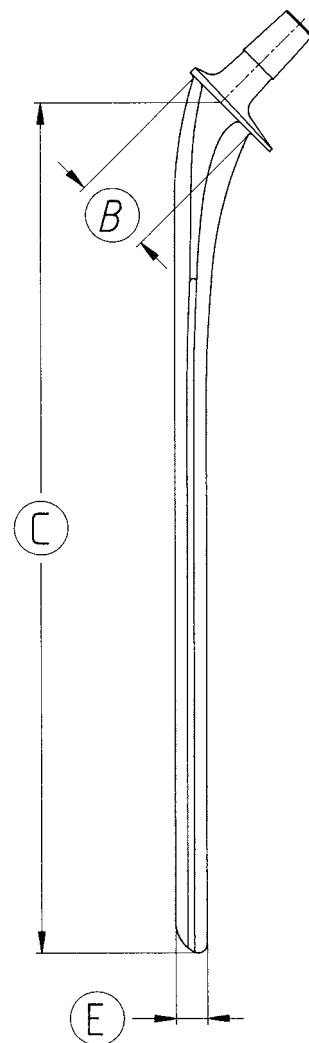
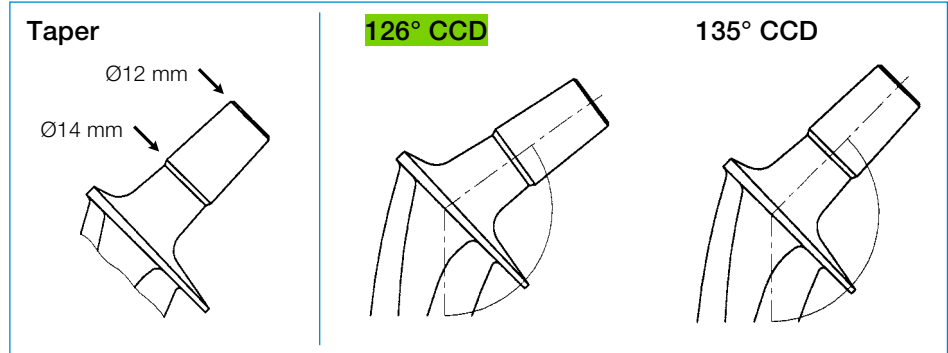

■ Implants

■ XL Prosthesis Stems Lubinus SPII[®], anatomical

Material: CoCrMo, taper 12/14 mm

- right and left version
- 4 stem lengths
- 3 stem sizes
- 2 CCD angles

CCD \triangleleft 126°		CCD \triangleleft 135°		Identification mark on collar	Stem width	Measurements				
Item no.	Item no.	ⓑ mm	ⓒ mm			ⓓ mm	ⓔ mm	ⓖ mm		
Version right										
127-910/26	127-910/35	R 2	medium	27.5	350	14	11	8		
127-912/26	127-912/35	R 3	large	29.5	350	15	12	9		
127-914/26	127-914/35	R 4	extra large	31.5	350	16	13	10		
127-916/26	127-916/35	R 2	medium	27.5	300	14	11	8		
127-918/26	127-918/35	R 3	large	29.5	300	15	12	9		
127-920/26	127-920/35	R 4	extra large	31.5	300	16	13	10		
127-922/26	127-922/35	R 2	medium	27.5	250	14	11	8		
127-924/26	127-924/35	R 3	large	29.5	250	15	12	9		
127-926/26	127-926/35	R 4	extra large	31.5	250	16	13	10		
127-928/26	127-928/35	R 2	medium	27.5	200	14	11	8		
127-930/26	127-930/35	R 3	large	29.5	200	15	12	9		
127-932/26	127-932/35	R 4	extra large	31.5	200	16	13	10		
Version left										
127-911/26	127-911/35	L 2	medium	27.5	350	14	11	8		
127-913/26	127-913/35	L 3	large	29.5	350	15	12	9		
127-915/26	127-915/35	L 4	extra large	31.5	350	16	13	10		
127-917/26	127-917/35	L 2	medium	27.5	300	14	11	8		
127-919/26	127-919/35	L 3	large	29.5	300	15	12	9		
127-921/26	127-921/35	L 4	extra large	31.5	300	16	13	10		
127-923/26	127-923/35	L 2	medium	27.5	250	14	11	8		
127-925/26	127-925/35	L 3	large	29.5	250	15	12	9		
127-927/26	127-927/35	L 4	extra large	31.5	250	16	13	10		
127-929/26	127-929/35	L 2	medium	27.5	200	14	11	8		
127-931/26	127-931/35	L 3	large	29.5	200	15	12	9		
127-933/26	127-933/35	L 4	extra large	31.5	200	16	13	10		

■ **XL Prosthesis Stems Lubinus SPII® XL Neck**

Material: CoCrMo, taper 12/14 mm

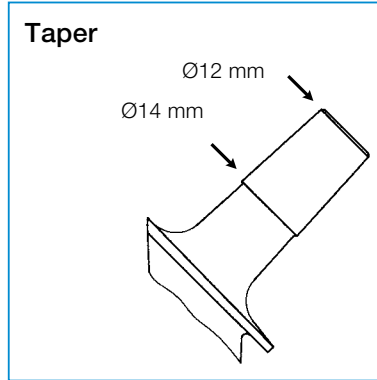

Each stems bears an identification mark on the upper side of the collar consisting of one letter and one number:

- R = right
- L = left
- 2 = medium
- 3 = large
- 4 = extra large

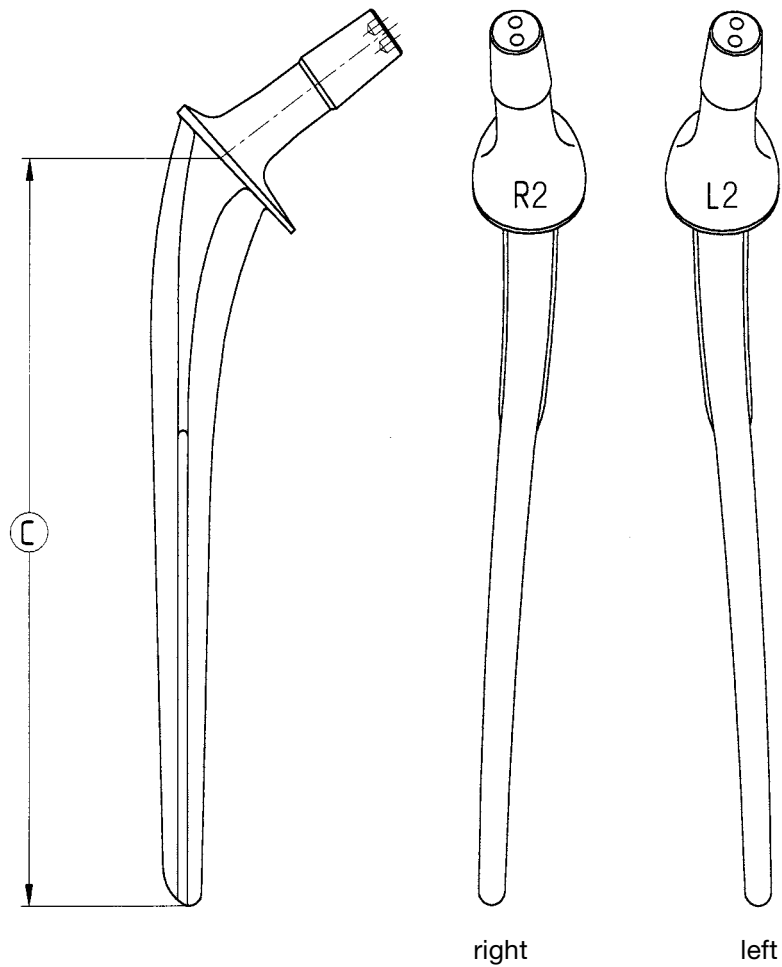

■ Implants

■ XL Prosthesis Stems Lubinus SPII® XL Neck

Material: CoCrMo, taper 12/14 mm

CCD \triangleleft 126°		CCD \triangleleft 135°			
Item no.	Item no.	Version	Stem length Ⓢ mm	Stem stem	Identification mark on collar
Version right					
127-940/26	127-940/35	right	350	medium	R2
127-942/26	127-942/35	right	350	large	R3
127-944/26	127-944/35	right	350	extra large	R4
127-946/26	127-946/35	right	300	medium	R2
127-948/26	127-948/35	right	300	large	R3
127-950/26	127-950/35	right	300	extra large	R4
127-952/26	127-952/35	right	250	medium	R2
127-954/26	127-954/35	right	250	large	R3
127-956/26	127-956/35	right	250	extra large	R4
127-958/26	127-958/35	right	200	medium	R2
127-960/26	127-960/35	right	200	large	R3
127-962/26	127-962/35	right	200	extra large	R4
Version left					
127-941/26	127-941/35	left	350	medium	L2
127-943/26	127-943/35	left	350	large	L3
127-945/26	127-945/35	left	350	extra large	L4
127-947/26	127-947/35	left	300	medium	L2
127-949/26	127-949/35	left	300	large	L3
127-951/26	127-951/35	left	300	extra large	L4
127-953/26	127-953/35	left	250	medium	L2
127-955/26	127-955/35	left	250	large	L3
127-957/26	127-957/35	left	250	extra large	L4
127-959/26	127-959/35	left	200	medium	L2
127-961/26	127-961/35	left	200	large	L3
127-963/26	127-963/35	left	200	extra large	L4

■ **Prosthesis Heads**

Prosthesis heads A - Ceramic

Material: BIOLOX® forte*



Item no.	Head Ø mm	Taper mm	Neck length (mm)
128-928/01	28	12/14	short (-3.5)
128-928/02	28	12/14	medium (0)
128-928/03	28	12/14	long (+3.5)
128-932/01	32	12/14	short (-4)
128-932/02	32	12/14	medium (0)
128-932/03	32	12/14	long (+4)
128-936/01	36	12/14	short (-4)
128-936/02	36	12/14	mittel (0)
128-936/03	36	12/14	lang (+4)

Prosthesis heads A - Ceramic

Material: BIOLOX® delta*



Item no.	Head Ø mm	Taper mm	Neck length (mm)
128-791/01	28	12/14	kurz (-3.5)
128-791/02	28	12/14	medium (0)
128-791/03	28	12/14	long (+3.5)
128-792/01	32	12/14	short (-4)
128-792/02	32	12/14	medium (0)
128-792/03	32	12/14	long (+4)
128-792/04**	32	12/14	extra long (+7)
128-793/01	36	12/14	short (-4)
128-793/02	36	12/14	medium (0)
128-793/03	36	12/14	long (+4)
128-793/04**	36	12/14	extra long (+8)

All BIOLOX® forte* and BIOLOX® delta* components are intercompatible.

* BIOLOX® delta and BIOLOX® forte are made by Ceramtec GmbH, Plochingen, Germany

Prosthesis heads B

Material: CoCrMo alloy



Item no.	Head Ø mm	Taper mm	Neck length (mm)
128-826/01	26	12/14	short (-3.5)
128-826/02	26	12/14	medium (0)
128-826/03	26	12/14	long (+3.5)
128-828/01	28	12/14	short (-3.5)
128-828/02	28	12/14	medium (0)
128-828/03	28	12/14	long (+3.5)
128-828/04**	28	12/14	extra long (+10.5)
128-832/01	32	12/14	short (-4)
128-832/02	32	12/14	medium (0)
128-832/03	32	12/14	long (+4)
128-832/04**	32	12/14	extra long (+8.5)
128-836/01	36	12/14	short (-4)
128-836/02	36	12/14	medium (0)
128-836/03	36	12/14	long (+4)
128-836/04**	36	12/14	extra long (+8)

** on request

■ Instruments

■ Colored Plastic Trial Heads



Colored plastic trial heads, taper 12/14 mm

Item no.	Ø	Neck length	Neck length mm	Color	Qty.
131-922/01*	22	short	-3.5	green	1
131-922/02*	22	medium	0	blue	1
131-924/01*	24	short	-3.5	green	1
131-924/02*	24	medium	0	blue	1
131-926/01*	26	short	-3.5	green	1
131-926/02*	26	medium	0	blue	1
131-926/03*	26	long	+3.5	black	1
131-928/11	28	short	-3.5	green	1
131-928/12	28	medium	0	blue	1
131-928/13	28	long	+3.5	black	1
131-928/14*	28	extra long	+10.5	brown	1
131-932/11	32	short	-4	green	1
131-932/12	32	medium	0	blue	1
131-932/13	32	long	+4	black	1
131-932/14*	32	extra long	+8.5	brown	1
131-936/11	36	short	-4	green	1
131-936/12	36	medium	0	blue	1
131-936/13	36	long	+4	black	1
131-936/14*	36	extra long	+8	brown	1

* on request

■ Instruments for Hip Implantation

Dederich bone retractor with hollow handle
The design makes it possible to hold the instrument comfortably for long periods.

Item no.	Version	Width	Length
15-1032	medium	18 mm	150 mm
15-1033	wide	43 mm	195 mm



Soft tissue retractors
with retrograde curved

Item no.	Version	Width	Length
66-3470	small	22 mm	325 mm
66-3472	wide	43 mm	325 mm



Hohmann retractor

Item no.	Version	Width	Length
130-100	small	10 mm	240 mm
130-105	medium	22 mm	260 mm
130-110	wide	43 mm	240 mm



■ Instruments

■ Instruments for Hip Implantation

130-114 LINK® bone retractor

with fenestrated handle

30 mm wide, 260 mm long



130-115 Rake retractor

6 pronged, with T-handle

210 mm



130-120

Bone hook

single prong, with T-handle

210 mm

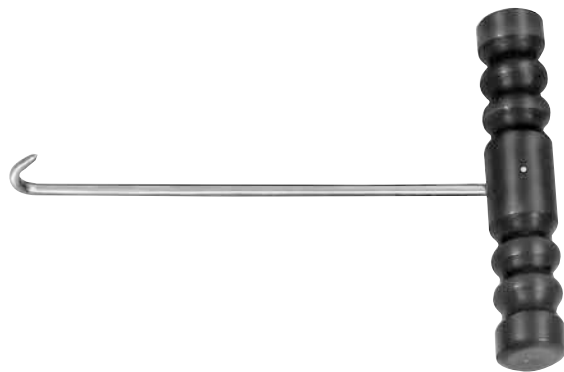

130-150

Femoral head extractor

270 mm



■ Instruments for Hip Implantation

130-155

LINK® Femoral head grasping forceps

285 mm

The forceps have triangular jaw sections at the ends of the branches with sharpened pins at the corners. The jaw sections are mobile and adjust well to the rounded contours of the bone. The handle has supports for the surgeon's hand. The folding latch allows the instrument to be used either with or without locking. The robust construction means that forceful manipulations are no problem.



68-1475

Bircher meniscus/cartilage clamp

with spiked jaws, 200 mm

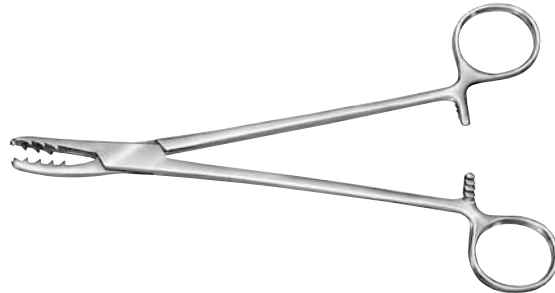

130-139

Cartilage scissors

250 mm

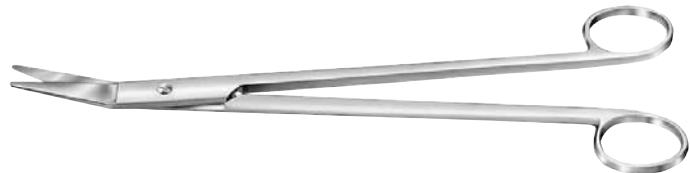

50-2562

Cartilage scissors

straight, 220 mm



50-2564

Cartilage scissors

curved, 220 mm



■ Instruments

■ Instruments for Hip Implantation

Thabe acetabulum excision forceps

240 mm

Item no.	Version
130-309/01	straight
130-309/02	curved

This forceps is constructed like a Rongeur. It has sharp cupped jaws with sharp teeth at the front. The forceps is designed for grasping coarse tissue and is particularly useful during the excision of the acetabular capsule.

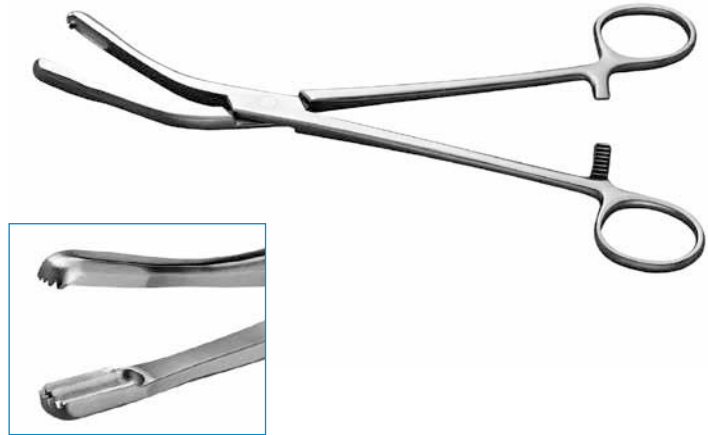

130-160

Lubinus Steinmann pin

with impact head and extraction hole
Ø 5 mm, 185 mm

Steinmann pins are hammered into the bone to keep the incision open. One is inserted into the ischium and another is placed about 2 cm above the cranial area of the cup.



To remove them a second pin is inserted through the hole in the head. The first pin can then be removed easily by turning.

Penetrating drill

with depth limitation, 150 mm

Choice of fittings

Item no.	Drill Ø
130-311/35	3.5 mm
130-311/50	5.0 mm



When ordering please indicate which fitting is required:

B Hudson, **C** Harris, **D** AO,
E Jacob's Chuck, **F** Trinkle

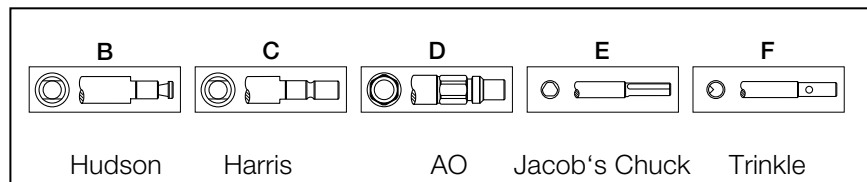

Example:

130-311/35C = with Harris fitting

130-686 Slotted driver for handle
(for rasp stems) and stem extractor
270 mm



■ Instruments for Hip Implantation

130-165 Mallet

Ø 30 mm, 270 mm, 600 g



Acetabular cup pusher with T-handle, 260 mm

Item no.	For acetabular cups
130-350	Inner Ø 32 mm
130-351	Inner-Ø 28 mm



Item no.	Replacement heads
130-350/02	for 130-350
130-351/02	for 130-351



130-350/05 T-handle, only

for cup pusher **130-350** and **130-351**



130-610 Cement packer

Ø 10 mm, 300 mm

Bone plug packer to insert bone plugs into the medullary cavity, 400 mm

Item no.	Ø
unthreaded	
131-200	8 mm
131-202	10 mm
131-204	12 mm
131-206	14 mm
131-208	16 mm
131-210	18 mm
threaded	
131-220	8 mm
131-222	10 mm
131-224	12 mm
131-226	14 mm
131-228	16 mm
131-230	18 mm

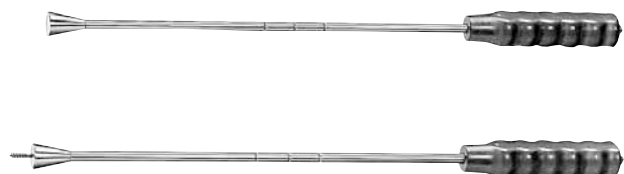

131-250/26 Inserter for intramedullary plugs graduated, 355 mm, set of 2



■ Instruments

■ Instruments for Hip Implantation

Intramedullary plugs

Item no.	Ø
109-130/12	12 mm
109-130/13	13 mm
109-130/14	14 mm
109-130/15	15 mm
109-130/16	16 mm
109-130/17	17 mm
109-130/18	18 mm
109-130/19	19 mm
109-130/20	20 mm



131-250/23 T-handle for inserter 131-250/26



15-1078/08 Key for Jakob's Chuck A

■ **Preoperative Planning**

Measurement tables and X-ray templates are available to aid preoperative planning of hip stem revision. They allow the surgeon to plan precisely which implants are to be used.

Exact preoperative planning is based on X-ray images which are either true to scale or supplied with precise details of the enlargement factor employed. LINK® X-ray templates use a standard enlargement factor of 110% when depicting implants. If different scales are required we can supply them as long as this is technically possible. On request we can provide producers of digital planning software with the relevant data in standard formats.

In spite of good preoperative planning, revision cases frequently involve extensive bone loss. This presents an unforeseeable challenge to surgeons that is rarely encountered in primary hip replacement. The procedures used to compensate for this bone loss vary greatly depending on the situation in the individual case. Where tumor prostheses are involved, structural changes in muscles/ ligaments, fixation etc. also need to be taken into account when planning surgery. As a result the treatment of patients with extensive bone loss represents a special problem and is subject to greater risk than is the implantation of normal hip prostheses.

■ **Surgical Technique**

Any implants in situ must be completely removed before a revision stem can be implanted. This can be performed either with specific instruments for the implant system being removed or with the LINK® revision instrument set, [130-698/01](#).

Any bone cement residues must be completely removed.

The femoral medullary cavity is drilled out with flexible intramedullary reamers or with ball reamers until the diameter is at least 2 mm greater than that of the chosen revision stem or the SPII® stem. The chosen stem can then be inserted into the femur for trial purposes.



Fig. 1
The medullary cavity is then cleaned using jet lavage.



Fig. 2
The depth for insertion of the medullary plug is measured against the implant.



Fig. 3
The medullary plug is inserted.



Fig. 4
Sufficient bone cement is prepared and then injected in a retrograde fashion.



Fig. 5
The chosen stem is first inserted by hand.

Note:
LINK® revision stems must be adjusted manually to achieve the required anteversion as this is not integrated into the stem.



Fig. 6
The hip stem is then advanced to the predetermined position using a pusher.



Fig. 7
Any overflow of bone cement is removed.



Fig. 8
The trial head is attached.
Trial reduction is carried out.



Fig. 9
After determining the final head neck length the head is implanted, the joint is reduced and leg length is checked again.

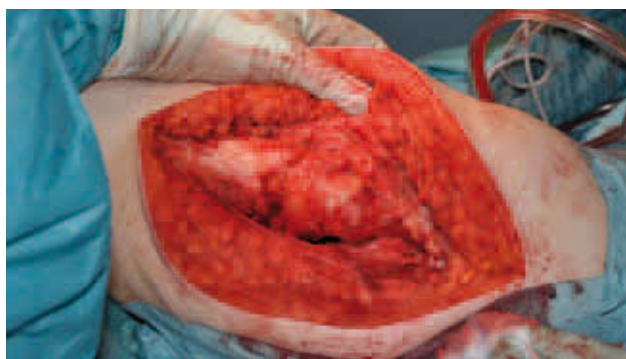



Fig. 10
Closure of the wound concludes the operation.

■ Accessories - Literature

■ X-ray Templates

X-ray templates for LINK® Endo-Model® Revision Stems, anatomical

Material: CoCrMo, head Ø 28 mm and 32 mm, taper 12/14 mm, 110 % natural size

Item no.	CCD 	Head Ø mm	for stem length mm	Set of sheets
15-1626/35	135°	28/32	170, 200, 250, 300	3

X-ray templates for LINK® Endo-Model® Revision Stems, straight

Material: CoCrMo, head Ø 28 mm and 32 mm, taper 12/14 mm, 110 % natural size

Item no.	CCD 	Head Ø mm	for stem length mm	Set of sheets
175-862/26	126°	28/32	130, 150, 170, 200, 250, 300	1
175-862/35	135°	28/32	130, 150, 170, 200, 250, 300	1

X-ray templates for LINK® XL Prosthesis Stems Lubinus SPII®, anatomical

Material: CoCrMo, head Ø 28 mm and 32 mm, taper 12/14 mm, 110 % natural size

Item no.	CCD 	Head Ø mm	for stem length mm	Set of sheets
131-423/26	126°	28/32	200, 250, 300, 350	4
131-423/35	135°	28/32	200, 250, 300, 350	4

X-ray templates for LINK® XL Prosthesis Stems Lubinus SPII® XL

Material: CoCrMo, head Ø 28 mm and 32 mm, taper 12/14 mm, 110 % natural size

Item no.	CCD 	Head Ø mm	for stem length mm	Set of sheets
131-414/26	126°	28/32	200, 250, 300, 350	3
131-414/35	135°	28/32	200, 250, 300, 350	3

■ Instructions of Cleaning and Maintenance

Instructions are available on request for each instrument set. Please mail customer@linkhh.de

■ Literature



Lubinus SPII®

Anatomically Adapted Hip Prosthesis System
Implants and Instruments & Surgical Technique
642_SPII_Impl. Instr. OP_en

“Totalendoprothese des Hüftgelenks”

H.W. Buchholz, E. Engelbrecht, J. Röttger, A. Siegel, Chir. Praxis 23, 297-306 (1977/78)

[H 16](#)

“Einfluß eines S-förmigen Hüftschafftdesigns (Lubinus SPII) auf die femorale Spannungsverteilung”

M. Lengsfeld, P. Alter, Th. Pressel, 1998 Orthopädie & ihre Grenzgebiete, Vol. 136 No. 5 Sept./Oct., p. A50

[H 94](#)

“Spannungsanalyse einer anatomisch adaptierten Femurschaftprothese (Lubinus SPII)”

P. Alter, M. Lengsfeld, J. Schmitt, 1999 Orthopädie & ihre Grenzgebiete, Vol. 137 No. 2 March/April

[H 95](#)

“Survival analysis of the cemented SPII stem”

Annaratone, Surace, Salerno, Regis, 2000, J Orthopaed Traumatol, 1:41-45, Springer.

[H 111](#)

“Prognosis of Total Hip Replacement”

H. Malchau, P. Herberts et al., 2002, Swedish National Hip Arthroplasty Register, Department of Orthopaedics, Gothenburg University, Sweden

[H 119](#)

“Cemented total hip arthroplasty: SPII: femoral component”

P. Lubinus, W. Klauser, B. Schwantes, R. Eberle, 2002 Giornale Italiano di Orthopedia e Traumatologia, Vol. XXVIII, Fasc. 6

[H 124](#)

“Can Finite Element Models Detect Clinically Inferior Cemented Hip Implants?”

J. Stolk, Clinical Orthopaedics and Related Research, 409; 138-150, 2003

[H 126](#)

LINK NEWS 16

Significance of the Lubinus SPII® hip prosthesis in the updated report of the Swedish National Total Hip Arthroplasty, Register from 1979 through 2002

Waldemar Link GmbH & Co. KG, 2004

[H 129](#)

“Migration of cemented Stem and Restrictor after Total Hip Arthroplasty”

F. Catani, A. Ensini, A. Leardini, L. Bragonzoni, Journal of Arthroplasty, Vol. 20, No. 2 2005, pp. 244-249

[H 139](#)

“Three hundred and twenty-one periprosthetic femoral fractures”

H. Lindahl, G. Garellick, H. Malchau, Journal of Bone and Joint Surgery, Vol. 88-A, No. 6 2006

[H 147](#)

“Socket wall addition device in the treatment of recurrent hip prosthesis dislocation ...”

A.G. Enocson, J. Minde, O. Svensson, Acta Orthopaedica Scandinavica 2006; 77 (1): 87-91

[H 148](#)

“Technik und Anwendungsmöglichkeiten der totalen Endoprothesen für das Hüftgelenk”

H.W. Buchholz, Langenbecks Arch. f. Chir. 325 (1969) 777

“Klassifikation und Behandlungsrichtlinien von Knochensubstanzverlusten bei Revisionsoperationen am Hüftgelenk - mittelfristige Ergebnisse.”

E. Engelbrecht, K. Heinert, Primär- und Revisions-Alloarthroplastik Hüft- und Kniegelenk. Berlin, Heidelberg, New York etc., Springer 1985, pp. 189-201

“Operationstechnik bei Hüftprothesenwechsel.”

E. Nieder, Symposium: Hüft- und Kniegelenksendoprothetik - aktueller Kenntnisstand, Zukunftsperspektiven. Orthopäd. Universitätsklinik Oskar-Helene-Heim Berlin, 27-28 March 1992, Berlin

■ Indications/Contraindications

■ Indications/Contraindications

Product	LINK® Endo-Model® Revision Stems XL Prosthesis Stems Lubinus SPII®
General Indications	
Mobility-limiting diseases, fractures or defects which cannot be treated by conservative or osteosynthetic procedures.	X
Indications	
Revision after implant loosening	X
Revision of femoral prosthesis components on peri-/subprosthetic fractures	X
Contraindications	
Poor general state of health	X
Acute and chronic infections, local and systemic	X
Allergies to (implant) materials	X
Distinctive muscular, nerve, vascular or other diseases which put the affected limb at risk.	X
Insufficient / inadequate bone mass- or quality which prevents a stable anchor of the prosthesis.	X
Relative Contraindications	
Adiposity	X
Lacking or foreseeable not assured compliance	X
Foreseeable overload/overstressing of the joint prosthesis	X
Osteoporosis	X

Please note:

These indications/contraindications refer to standard cases. The ultimate decision on whether or not an implant is suitable for a patient must be made by the surgeon based on his/her individual analysis and his/her experience.

■ Numerical Index

	Page
15-1032, 15-1033	19
15-1626/35	22
15-1717/01 to 15-1717/36	11
50-2562, 50-2564	21
66-3470, 66-3472	19
68-1475	21
109-130/12 to 109-130/20	24
125-500/26 to 125-525/26	13
125-500/35 to 125-525/35	13
127-910/26 to 127-933/26	15
127-910/35 to 127-933/35	15
127-940/26 to 127-963/26	17
127-940/35 to 127-963/35	17
130-100 to 130-110	19
130-114, 130-115	20
130-120	20
130-139	21
130-150	20
130-155	21
130-160	22
130-165	23
130-309/01, 130-309/02	22
130-311/35, 130-311/50	22
130-350/05	23
130-350, 130-351	23
130-350/02, 130-351/02	23
130-610	23
130-686	22
131-200 to 131-210	23
131-220 to 131-230	23
131-250/23	24
131-250/26	23
131-414/26, 131-414/35	22
131-423/26, 131-423/35	22
131-926/01 to 131-926/03	18
131-928/01 to 131-928/04	18
131-932/01 to 131-932/04	18
131-936/01 to 131-936/04	18
175-862/26, 175-862/35	22

■ Important Information

Please note the following regarding the use of our implants:

1. Choosing the right implant is very important.

The size and shape of the human bone determine the size and shape of the implant and also limit the load capacity. Implants are not designed to withstand unlimited physical stress. Demands should not exceed normal functional loads.

2. Correct handling of the implant is very important.

Under no circumstances should the shape of a finished implant be altered, as this shortens its life span. Our implants must not be combined with implants from other manufacturers.

The instruments indicated in the Surgical Technique must be used to ensure safe implantation of the components.

3. Implants must not be reused.

Implants are supplied sterile and are intended for single use only. Used implants must not be reused.

4. After-treatment is also very important.

The patient must be informed of the limitations of the implant. The load capacity of an implant cannot compare with that of healthy bone!

5. Unless otherwise indicated, implants are supplied in sterile packaging.

Note the following conditions for storage of packaged implants:

- Avoid extreme or sudden changes in temperature.
- Sterile implants in their original, intact protective packaging may be stored in permanent buildings up until the "Use by" date indicated on the packaging.
- They must not be exposed to frost, dampness or direct sunlight, or mechanical damage.
- Implants may be stored in their original packaging for up to 5 years after the date of manufacture. The "Use by" date is indicated on the product label.
- Do not use an implant if the packaging is damaged.

6. Traceability is important.

Please use the documentation stickers provided to ensure traceability.

7. Further information on the material composition is available on request from the manufacturer.

Follow the instructions for use!

Waldemar Link GmbH & Co. KG, Hamburg

All content in this catalog, including text, pictures and data, is protected by copyright. Every instance of use, whether in part or in whole and which is not permitted by the copyright act, is subject to our prior consent. In particular, this applies to the reproduction, editing, translation, publishing, saving, processing, or passing on of content stored in databases or other electronic media and systems, in any manner or form. The information in the catalogs is solely intended to describe the products and does not constitute a guarantee.

The Surgical Technique described has been written to the best of our knowledge and belief, but it does not relieve the surgeon of his/her responsibility to duly consider the particularities of each individual case.

Unless otherwise indicated, all instruments are made of surgical stainless steel.



Waldemar Link GmbH & Co. KG

Barkhausenweg 10 · 22339 Hamburg, Germany
P.O. Box 63 05 52 · 22315 Hamburg, Germany
Tel.: +49 40 53995-0 · Fax: +49 40 5386929
E-mail: info@linkhh.de · www.linkorthopaedics.com

LINK[®]

